

**CONSTRUCTION AND DEMOLITION NOTES:**

- (100) RETAIN AND PROTECT SURVEY MONUMENT.
- (101) CITY CREW TO REMOVE, SALVAGE, AND REINSTALL SIGN TO NEW LOCATION AS DIRECTED BY THE CITY OF COTTAGE GROVE PUBLIC WORKS DIRECTOR.
- (102) RETAIN AND PROTECT EXISTING FENCE.
- (103) PROTECT EXISTING ELECTRIC VAULT.
- (104) PROTECT EXISTING UTILITY POLE AND GUY ANCHOR.
- (105) PROTECT EXISTING UTILITY. ADJUST BOX TO FINISHED GRADE AS NEEDED PER PUBLIC IMPROVEMENT PLANS, SHEETS C300 & C301 AND GRADING & PAVING PLAN SHEET C201.
- (106) PROTECT EXISTING SIGN.
- (107) **COORDINATE WITH OWNER FOR REMOVAL AND RELOCATION OF SIGN AS NECESSARY. CONFIRM IF OWNER WANTS SIGN REINSTALLED.**
- (108) REMOVE EXISTING SHRUB.
- (109) PROTECT EXISTING AREA DRAIN. INSTALL SEDIMENT PROTECTION AT EXISTING AREA DRAIN.
- (110) REMOVE EXISTING TREE AND GRATE W/CONCRETE COLLAR. RETURN GRATE TO THE CITY OF COTTAGE GROVE.
- (111) PROTECT EXISTING WATER LINE.
- (112) PROTECT EXISTING STORMDRAIN LINE.
- (114) PROTECT EXISTING WATER OR IRRIGATION VALVE. ADJUST RIM TO FINISHED GRADE AS NEEDED PER PUBLIC IMPROVEMENTS PLANS, SHEETS C300 & C301 AND GRADING & PAVING PLAN SHEET C201.
- (115) PROTECT EXISTING CATCH BASIN. INSTALL SEDIMENT PROTECTION AT EXISTING CATCH BASIN.
- (116) PROTECT EXISTING OVERHEAD UTILITY LINE.
- (117) PROTECT EXISTING UNDERGROUND FIBER OPTIC LINE THAT IS 36" BELOW GRADE PER LUMEN.
- (120) SAWCUT EXISTING AC PAVEMENT. PROTECT SAWCUT EDGE FROM DAMAGE.
- (121) SAWCUT EXISTING CONCRETE. PROTECT SAWCUT EDGE FROM DAMAGE.
- (127) EXISTING UTILITY POLE (PPL 20-03 POLE INVENTORY #284206) TO BE REMOVED AND ELECTRICAL JUNCTION BOX, GUY ANCHOR, AND ELECTRIC CONDUITS TO BE RELOCATED. CONTRACTOR TO COORDINATE WORK WITH PACIFIC POWER (ELKE VATH 541-967-6160).
- (128) EXISTING UTILITY POLE (PPL 20-03 POLE INVENTORY #284109), GUY ANCHOR, AND ELECTRIC CONDUITS TO BE RELOCATED. CONTRACTOR TO COORDINATE WORK WITH PACIFIC POWER (ELKE VATH 541-967-6160).
- (129) REMOVE "NO PARKING" SIGN AND RETURN TO THE CITY OF COTTAGE GROVE.
- (132) **PROTECT EDGE OF PAVEMENT.**
- (133) PROTECT EXISTING WASTEWATER LINE.
- (134) PROTECT EXISTING TREE.
- (905) INSTALL EDA PROJECT SIGN. CONTRACTOR SHALL SUPPLY, ERECT, AND MAINTAIN SIGN IN GOOD CONDITION DURING CONSTRUCTION ACCORDING TO EDA SITE SIGN SPECIFICATIONS.

**LEGEND**

**EXISTING**

- APPROX. PROPERTY LINE
- 647--- EXISTING CONTOUR
- CURB
- EDGE OF ASPHALT
- FENCE LINE
- CENTERLINE OF RAILROAD
- (E)OHW--- OVERHEAD WIRES
- W--- WATER LINE
- (E)SD--- STORM SEWER LINE
- (E)FO--- FIBER OPTIC LINE
- (E)WW--- WASTEWATER LINE

- CONCRETE
- GRAVEL
- WATER VALVE
- IRRIGATION VALVE
- WATER METER
- CATCH BASIN
- POWER POLE
- POWER POLE /w ARM
- GUY ANCHOR
- SIGN
- LIGHT POLE

- 647.00 SPOT ELEVATION
- TL TAX LOT NUMBER
- ELECTRIC BOX
- JUNCTION BOX
- ELECTRIC VAULT
- SD MANHOLE
- SS CLEANOUT
- DECIDUOUS TREE
- EVERGREEN TREE

**PROPOSED**

- DEMO CONCRETE
- DEMO ASPHALT
- SAWCUT LINE

**NOTE**

1. THE LOCATION OF EXISTING UNDERGROUND UTILITIES ARE SHOWN IN AN APPROXIMATE WAY ONLY AND HAVE NOT BEEN INDEPENDENTLY VERIFIED BY THE OWNER OR ITS REPRESENTATIVE. THE CONTRACTOR SHALL DETERMINE THE EXACT LOCATION OF ALL EXISTING UTILITIES BEFORE COMMENCING WORK, AND AGREES TO BE FULLY RESPONSIBLE FOR ANY AND ALL DAMAGES WHICH MIGHT BE OCCASIONED BY THE CONTRACTOR'S FAILURE TO EXACTLY LOCATE AND PRESERVE ANY AND ALL UNDERGROUND UTILITIES. THE CONTRACTOR SHALL CONTACT UNDERGROUND SERVICE ALERT (USA) AT (800) 227-2600 TO INDICATE EXISTING UTILITIES AT LEAST 48 HOURS PRIOR TO BEGINNING WORK. THE CONTRACTOR SHALL TAKE PRECAUTIONARY MEASURES TO PROTECT THESE UTILITIES. THE CONTRACTOR SHALL DO NO EXCAVATION UNTIL ALL UTILITY AGENCIES AND THE CITY HAVE BEEN NOTIFIED AND HAVE BEEN GIVEN THE OPPORTUNITY TO MARK THEIR FACILITIES IN THE FIELD.

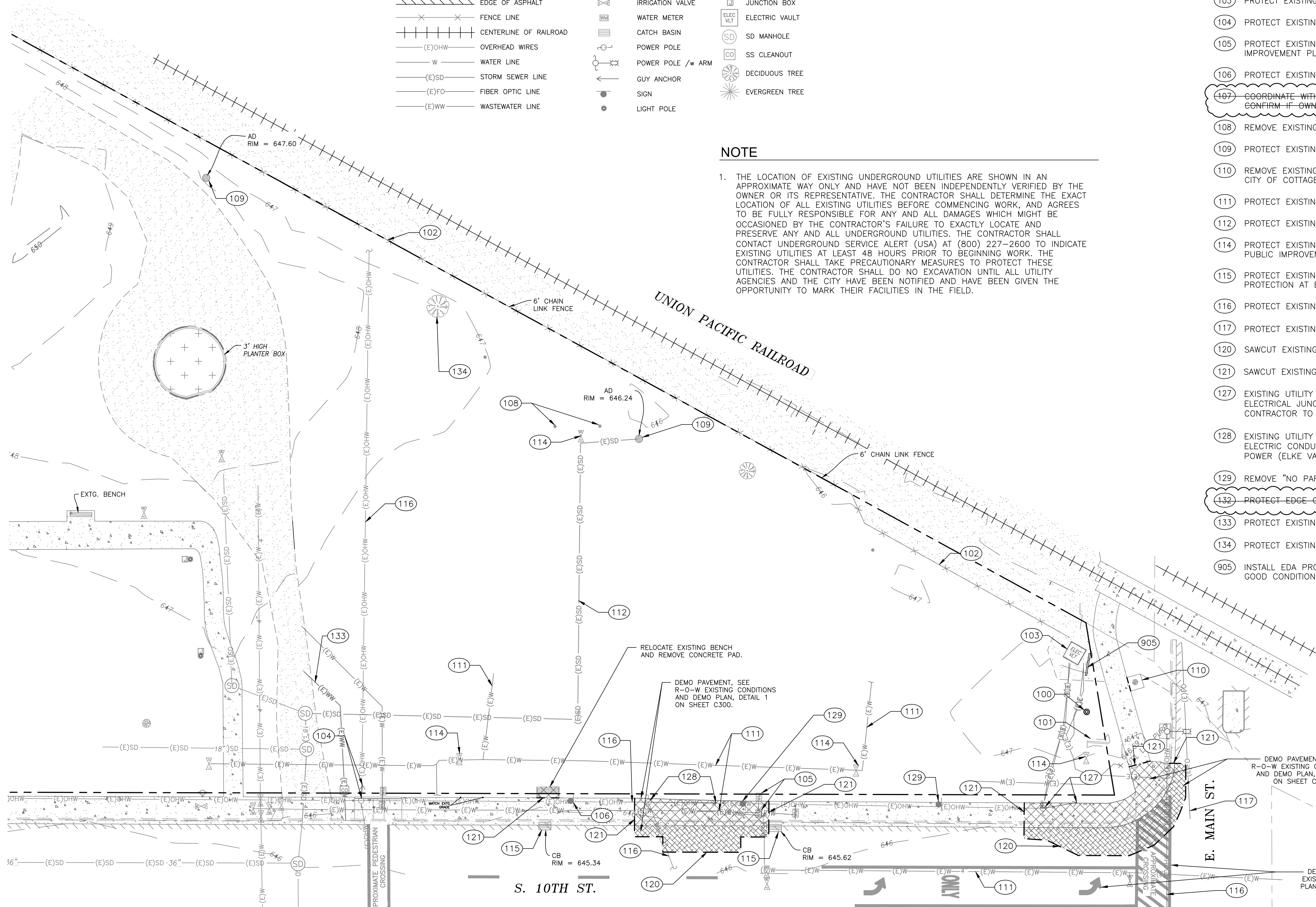

**ABBREVIATIONS**

AC	ACRE(S)	EXTG.	EXISTING
AD	AREA DRAIN	PROP.	PROPOSED
BP	ALIGNMENT BEGINNING POINT	SAN	SANITARY
C	CONCRETE	IE	INVERT ELEVATION
CB	CATCH BASIN	ELEV.	ELEVATION
CL	CENTERLINE	FG	FINISHED GRADE
DCVA	DOUBLE CHECK VALVE ASSEMBLY	EG	EXISTING GRADE
BW	BACK OF WALK	ODOT	OREGON DEPARTMENT OF TRANSPORTATION
MAX.	MAXIMUM		
MH	MANHOLE	PT	ALIGNMENT POINT OF TANGENCY
MID	ALIGNMENT MID POINT		
MIN.	MINIMUM	R-0-W	RIGHT OF WAY
PSI	POUNDS PER SQUARE INCH	RG	RAIN GARDEN
STD.	STANDARD	TC	TOP OF CURB
DWG	DRAWING	SS	SANITARY SEWER
W/L	WATERLINE	SD	STORM DRAIN
EP	ALIGNMENT END POINT	STA	STATION
EX.	EXISTING	STM	STORM
		WW	WASTEWATER

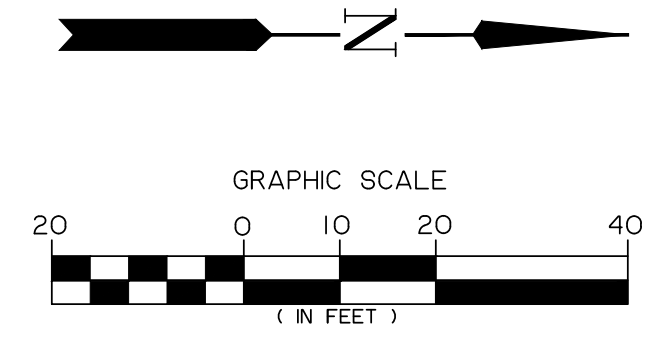

2/1/2024 12:01 PM Bohemia Park Expansion (Drawings) M02001A12-0011 Bohemia Park Expansion\_04/26/2024 4:25 PM JPH/PHZ

**Branch ENGINEERING**  
Since 1977  
civil • transportation  
structural • geotechnical  
SURVEYING  
310 5th Street  
Springfield, OR 97477  
P: 541.746.6637  
www.BranchEngineering.com

REGISTERED PROFESSIONAL  
ENGINEER  
#86136PE  
DIGITALLY SIGNED  
OREGON  
JAN. 8. 2019  
JULIE LYNN LELAND  
Expires: DEC 31, 2024

**CITY OF COTTAGE GROVE ENGINEERING**  
400 Main Street Cottage Grove, OR 97424

**REVISIONS:**

No.	DESCRIPTION	DATE
Δ	REMOVE CONSTRUCTION NOTES 107 AND 132	4/26/24

**CITY OF COTTAGE GROVE  
BOHEMIA PARK EXPANSION**

EXISTING CONDITIONS AND DEMO PLAN

Sheet No. **C100**

Job No. 22-001K

DRAWN BY: ZZ CHECKED BY: DG DATE: 04/10/24



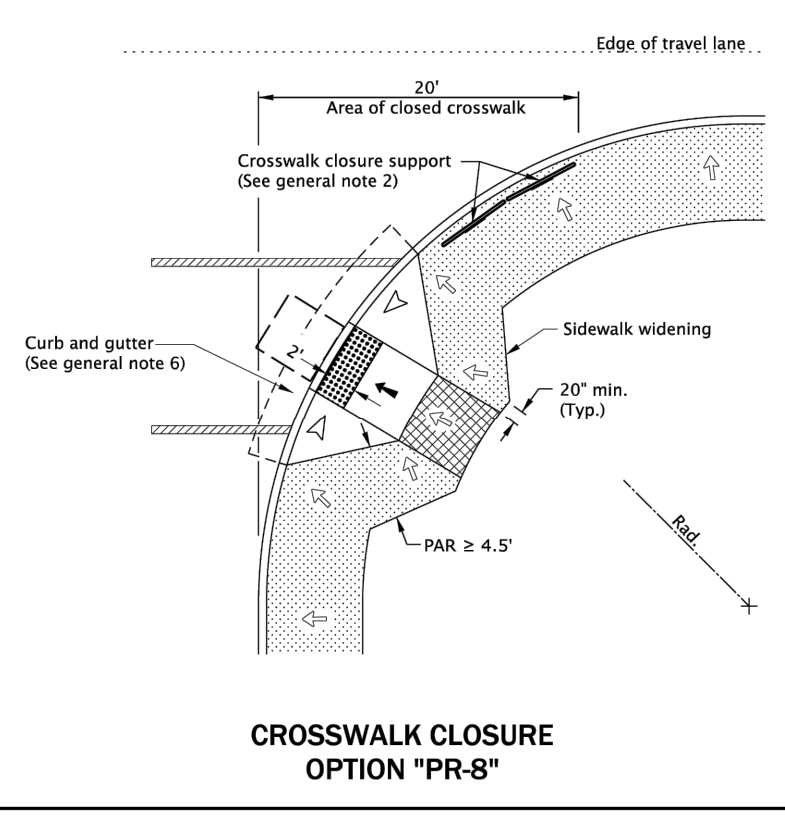
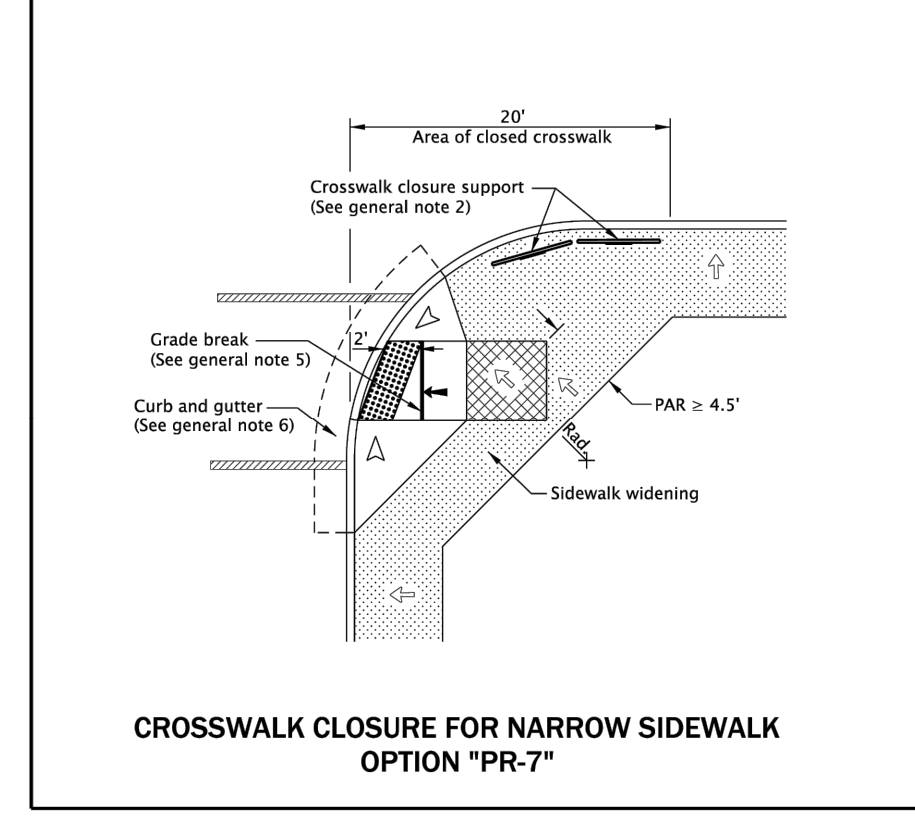
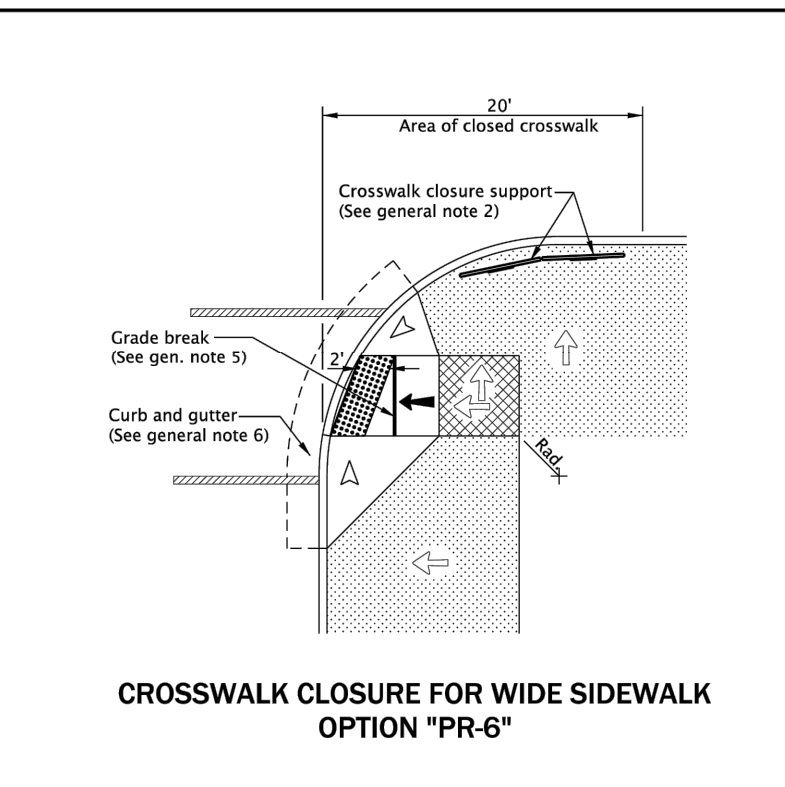
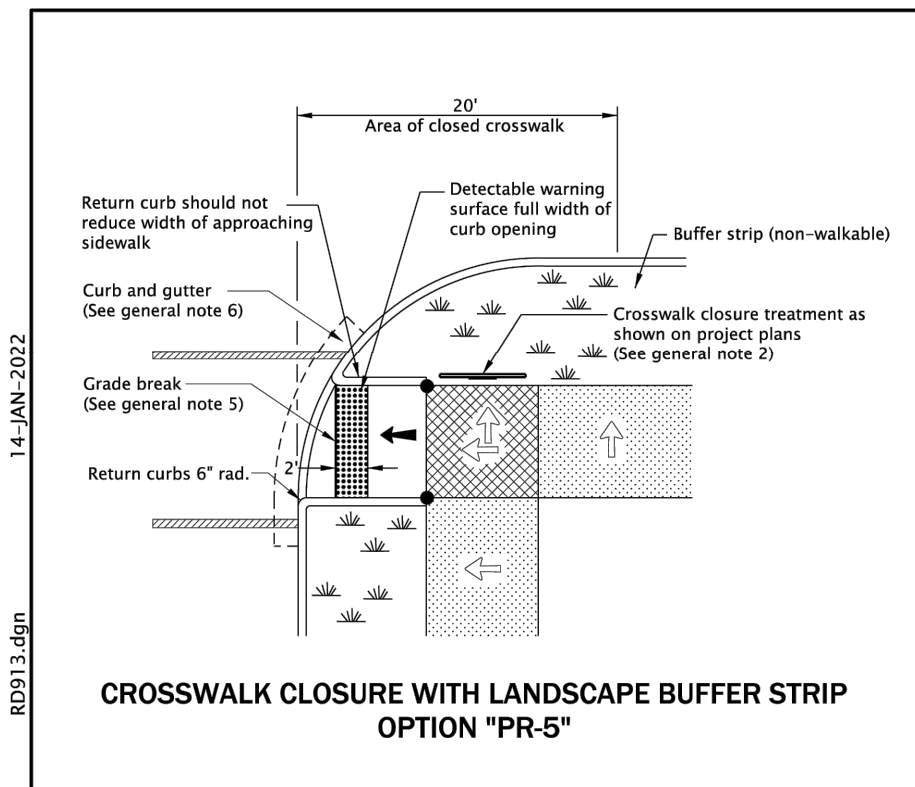

GENERAL NOTES FOR ALL DETAILS ON THIS SHEET:

- Curb ramp details are based on applicable ODOT standards.
- See project plans for details not shown. See Std. Dwg. RD700 & RD701 for curbs. See Std. Dwg. RD720 & RD721 for sidewalks. See Std. Dwg. RD910 for perpendicular curb ramp details. See Std. Dwg. RD900 through RD909 for detectable warning surface installation details. See Std. Dwg. TM240 for crosswalk closure detail.
- Tooled dummy joints are required at all curb ramp grade break lines. (See Std. Dwg. RD722).
- Curb ramp slopes shown are relative to the true level horizon (zero bubble).
- Grade breaks at the top and bottom of curb ramp runs shall be perpendicular to the direction of the ramp run. Grade breaks shall not be permitted on the surface of ramp runs and turning spaces. Surface slopes that meet at grade breaks shall be flush.
- On or along state highways, curb and gutter is required at curb ramps.

LEGEND:

- Marked or intended crossing location
- Sidewalk
- Detectable warning surface
- Level area (Turning space/landing) Unobstructed 4.5' x 4.5' With obstruction 4.5' x 5.5' (Longer dimension in direction of pedestrian street crossing). For the purposes of this application, a max. 2.0% finished surface slope (for drainage) measured perpendicular in two directions is considered level.
- Cross slope 1.5% max. (Max. 2.0% finished surface slope) (Normal sidewalk cross slope)
- Running slope 7.5% max. (Max. 8.3% finished surface slope)
- Flare slope (Max. 10% finished surface slope)
- Zero curb exposure
- 4' x 4' clear space
- PAR Pedestrian Access Route

The selection and use of this Standard Drawing, while designed in accordance with generally accepted engineering principles and practices, is the sole responsibility of the user and should not be used without first consulting a Registered Professional Engineer.

Effective Date: December 1, 2023 - May 31, 2024

RD913

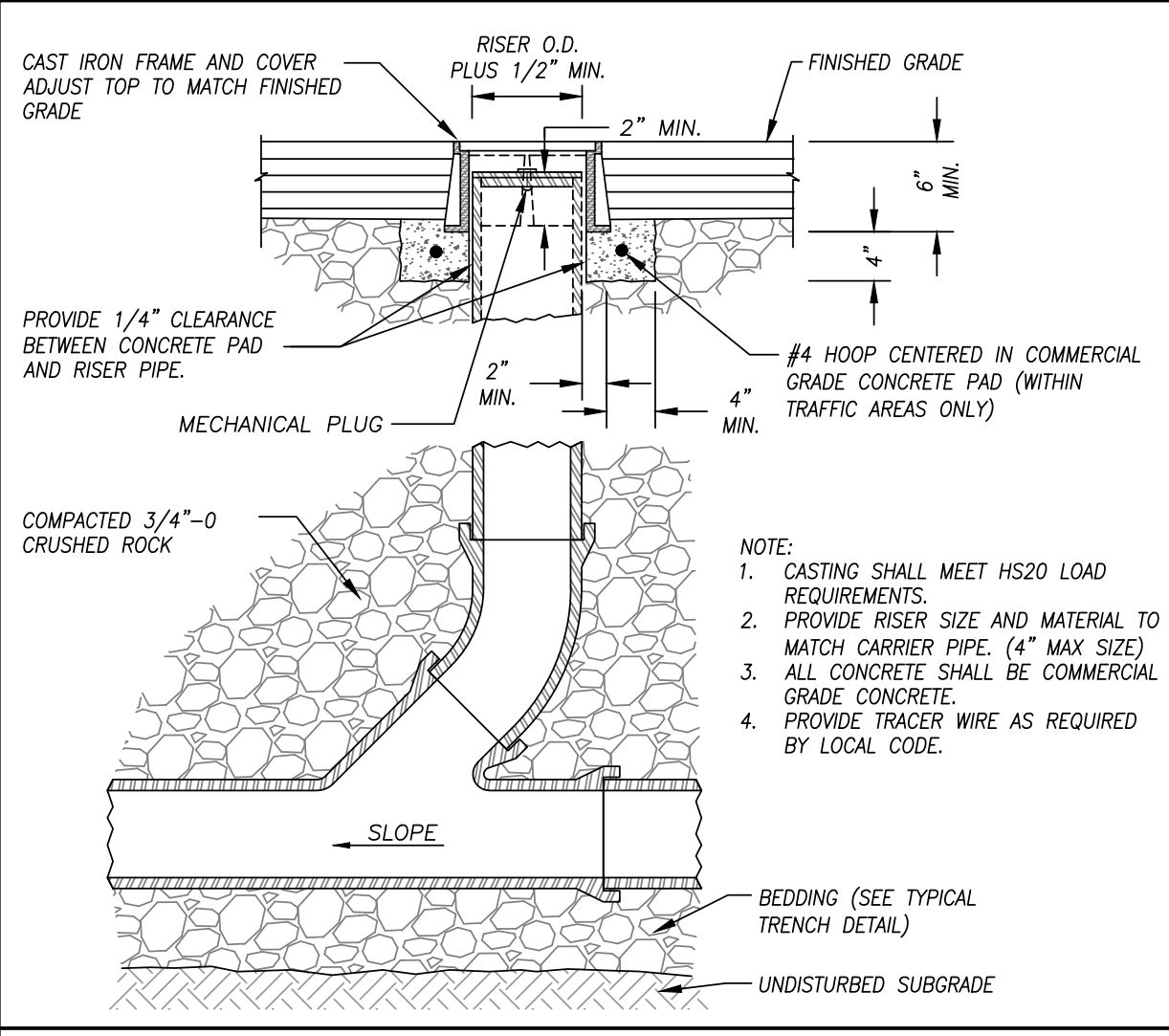

1 CLEANOUT SCALE: N.T.S.

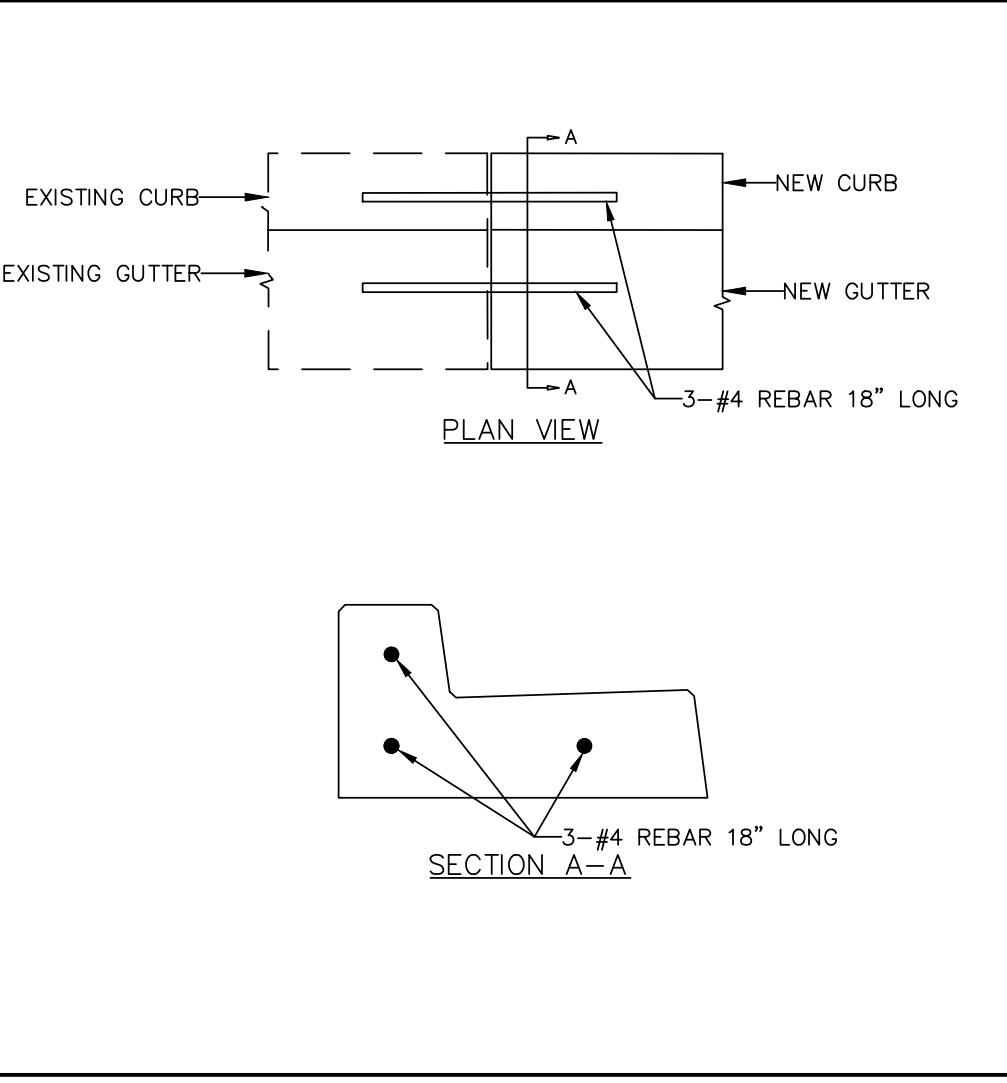

2 TIE IN NEW C&G TO EXISTING C&G SCALE: N.T.S.

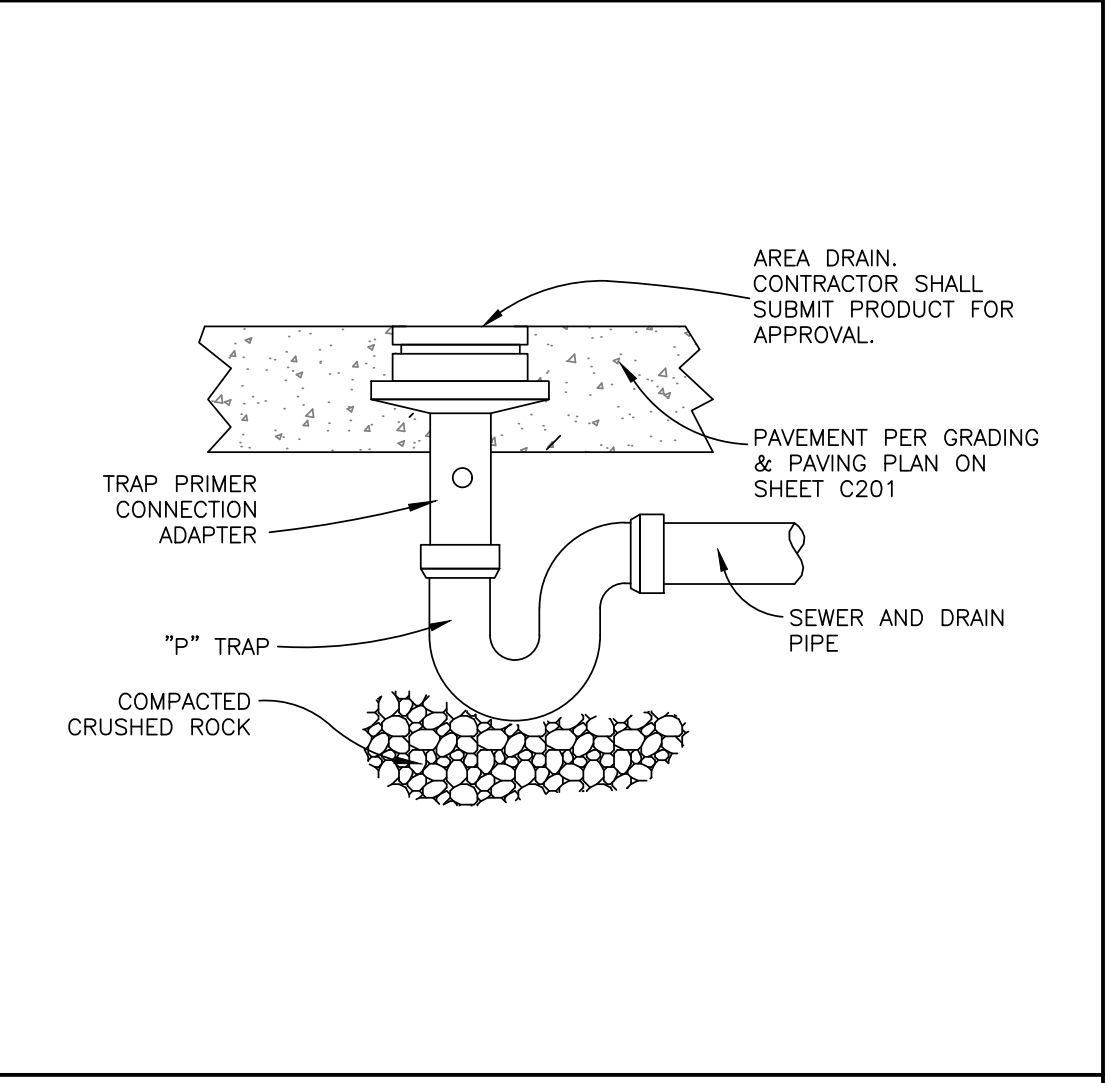

3 AREA DRAIN SCALE: N.T.S.

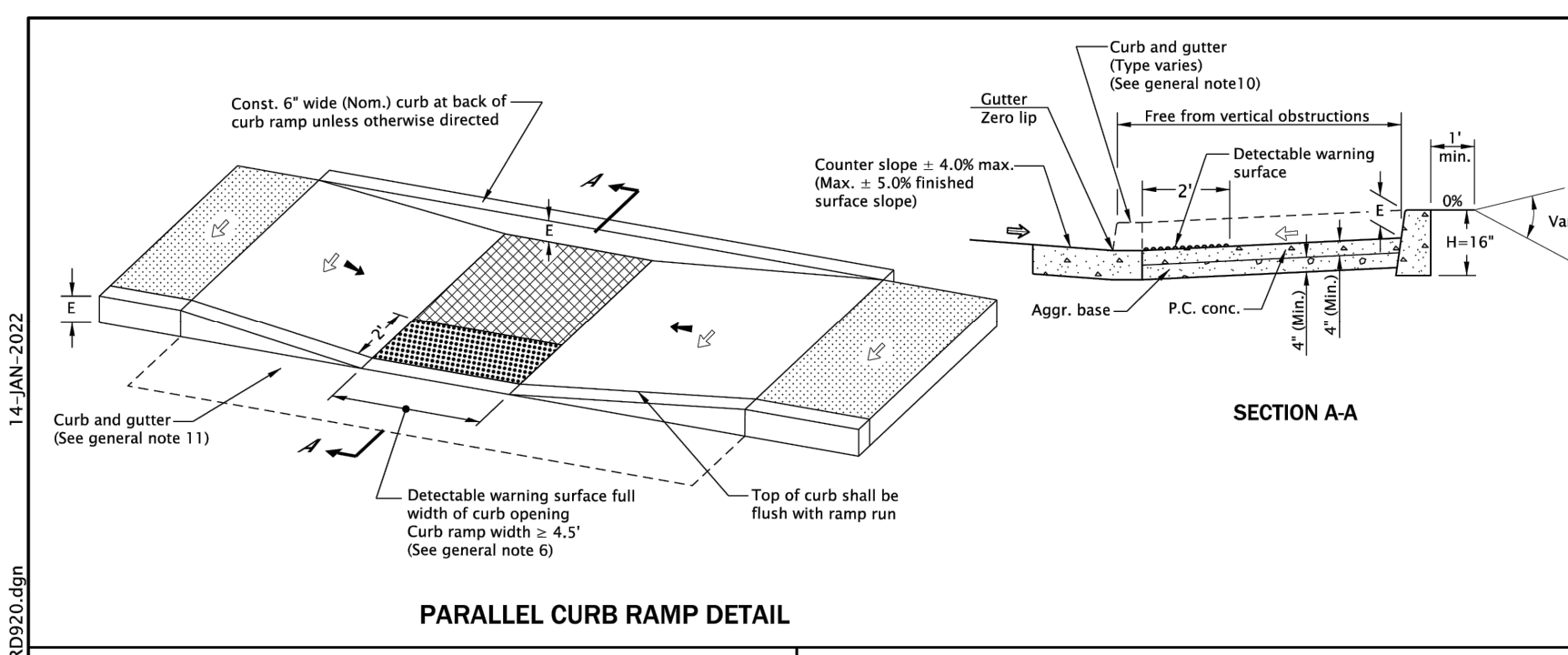

GENERAL NOTES FOR ALL DETAILS ON THIS SHEET:

- Curb ramp details are based on applicable ODOT Standards.
- See Std. Dwg. RD700 & RD701 for curbs. See Std. Dwg. RD720 & RD721 for sidewalks. See Std. Dwg. RD900 through RD909 for detectable warning surface installation details. See Std. Dwg. TM240 for crosswalk closure detail.
- Site conditions normally require a project specific design. See project plans for details not shown.
- Tooled dummy joints are required at all curb ramp grade break lines. (See Std. Dwg. RD722).
- Curb ramp slopes shown are relative to the true level horizon (zero bubble).
- Place detectable warning surface at the back of curb for a minimum depth of 2' in the direction of pedestrian travel full width of curb ramp opening that is adjacent to traffic.
- Grade breaks at the top and bottom of curb ramp runs shall be perpendicular to the direction of the ramp run. Grade breaks shall not be permitted on the surface of ramp runs and turning spaces. Surface slopes that meet at grade breaks shall be flush.
- When 2 ramp runs are immediately adjacent, the curb exposure (E) between the adjacent side may range between 3' and full design exposure.
- Curb ramps for shared use paths intersecting a roadway shall be full width of path, excluding flares. When a curb ramp is used to provide stoic access from a roadway to a sidewalk, the curb ramp opening will be  $\geq$  8' wide, (see Std. Dwg. RD909 for additional details).
- Place an inlet at upstream side of curb ramp or perform other approved design mitigation. Check the gutter flow depth at curb ramp locations to assure that the design flood does not overlap the back of sidewalk.
- On or along state highways, curb and gutter is required at curb ramps.

LEGEND:

- Sidewalk
- Detectable warning surface
- Level area (Turning space/landing) Unobstructed 4.5' x 4.5' With obstruction 4.5' x 5.5' (Longer dimension in direction of pedestrian street crossing). For the purposes of this application, a max. 2.0% finished surface slope (for drainage) measured perpendicular in two directions is considered level.
- Cross slope 1.5% max. (Max. 2.0% finished surface slope) (Normal sidewalk cross slope)
- Running slope 7.5% max. (Max. 8.3% finished surface slope)
- Counter slope 4.0% max. ascending or descending. (Max. 5.0% finished surface slope) Slope as required for drainage
- 4'x4' clear space

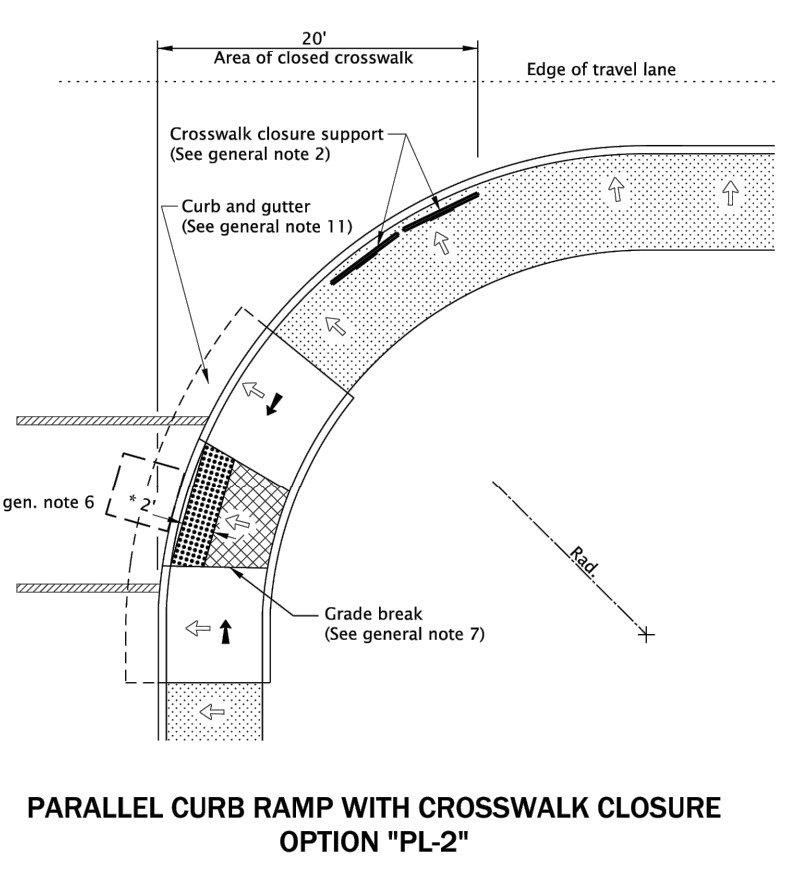
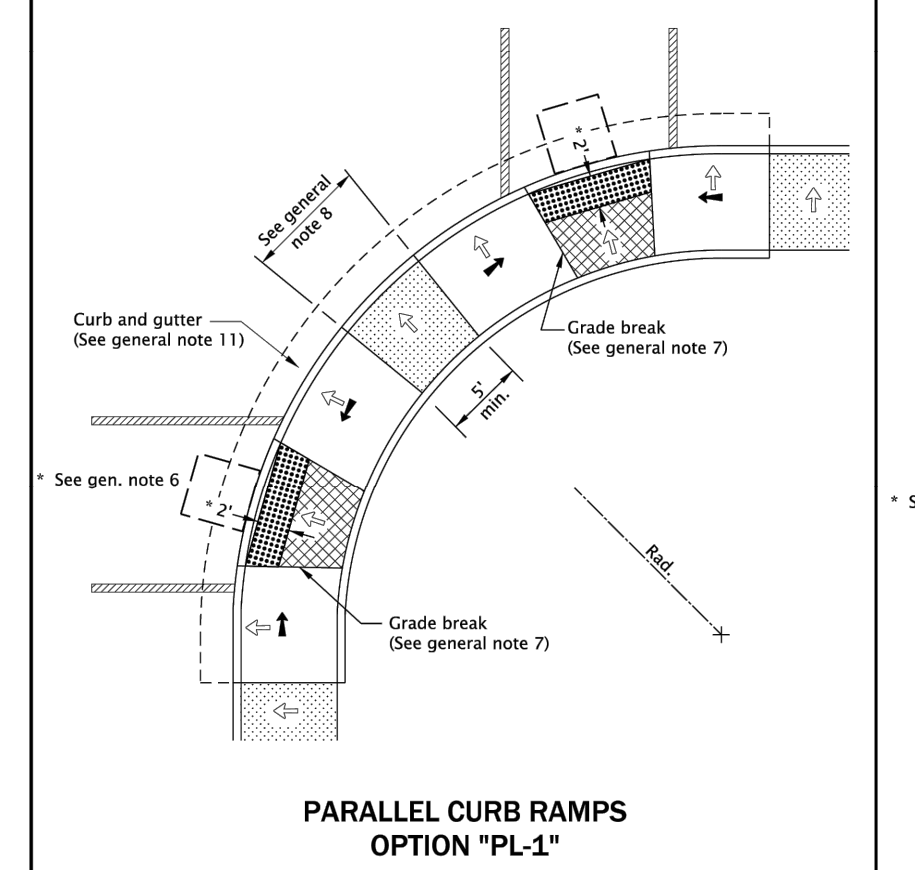

The selection and use of this Standard Drawing, while designed in accordance with generally accepted engineering principles and practices, is the sole responsibility of the user and should not be used without first consulting a Registered Professional Engineer.

Effective Date: December 1, 2023 - May 31, 2024

RD920

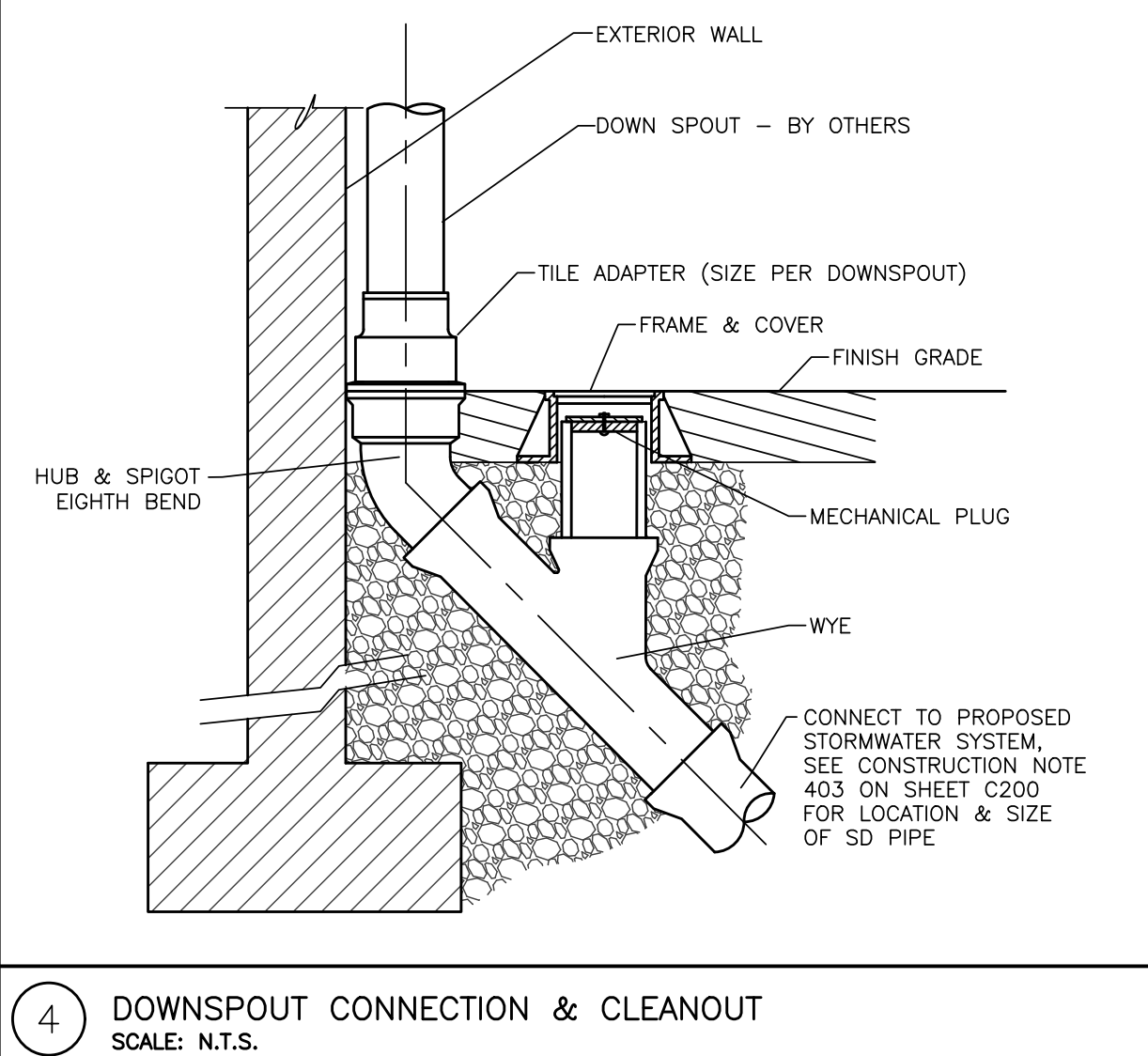

4 DOWNSPOUT CONNECTION & CLEANOUT SCALE: N.T.S.

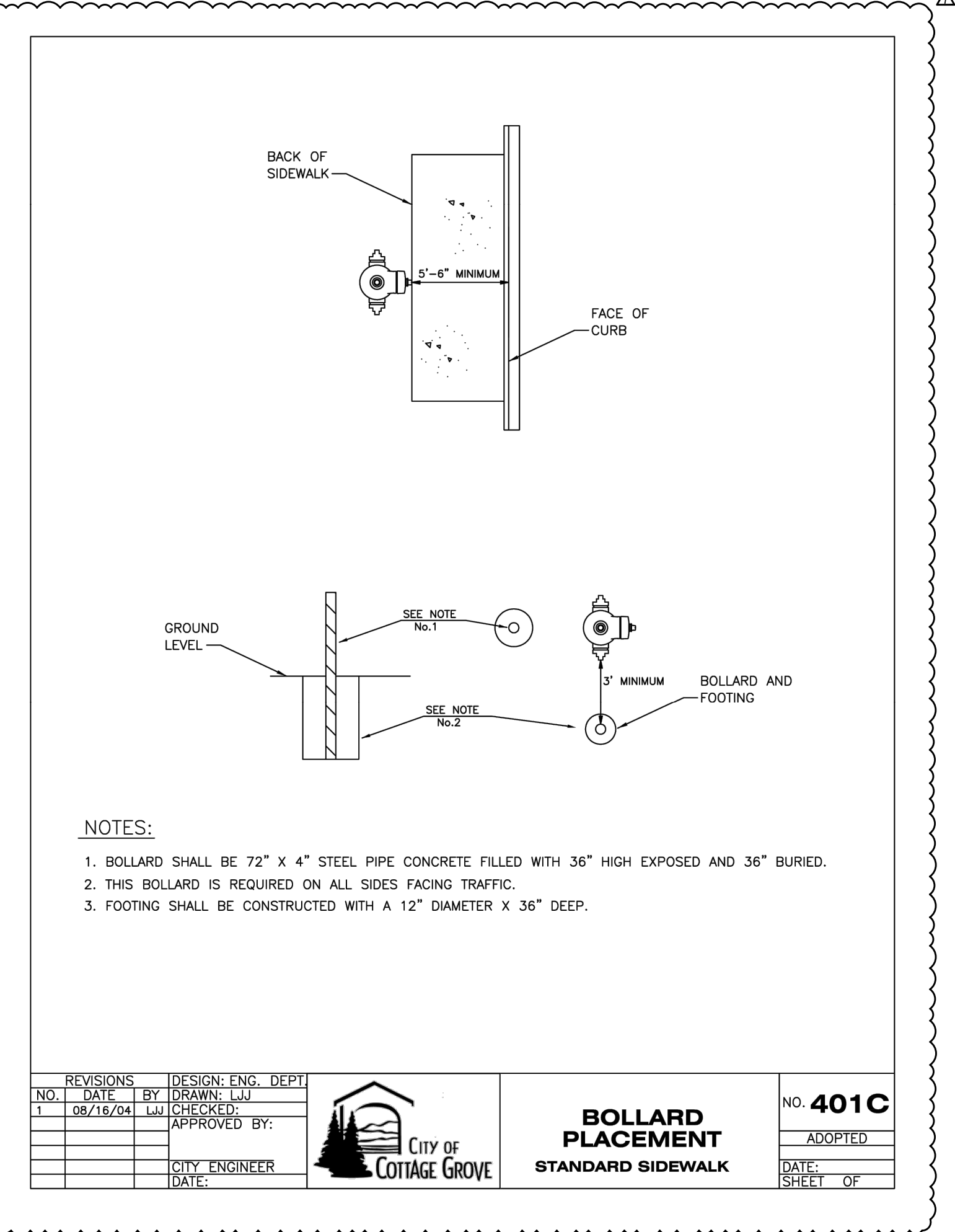

Branch ENGINEERING Since 1977  
civil • transportation structural • geotechnical SURVEYING  
310 5th Street Springfield, OR 97477  
p: 541.748.0637  
www.BranchEngineering.com

REGISTERED PROFESSIONAL ENGINEER #86136PE  
DIGITALLY SIGNED OREGON  
JULIE LYNN LELAND  
JAN. 8. 2019  
Expires: DEC 31, 2024

CITY OF COTTAGE GROVE ENGINEERING  
400 Main Street Cottage Grove, OR 97424

REVISIONS:

No.	DESCRIPTION	DATE
Δ	ADJUST TRANSFORMER ADD BOLLARD DETAIL	4/26/24

CITY OF COTTAGE GROVE  
BOHEMIA PARK EXPANSION

CIVIL DETAILS

Sheet No. **C402**

DRAWN BY: ZZ  
CHECKED BY: DG  
DATE: 04/10/24

JOB No. 22-001K

21/0027 (2-2014) Cottage Grove Bohemia Park Expansion Drawings\A02001A12-0011 Bohemia Park Expansion\_DWG204\_0426/2024\_4:25 PM JPH/INTZ